

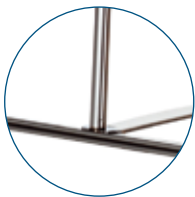

# Maxibit Solo, Banner Stand



### Maxibit Solo 1

Characterised by its unique back-foot, Solo 1's light frame is barely visible from the front, allowing your brand to take all the attention. Solo 1 stands as a definitive structure on the floor, comes in a width of 82 cm, and can also be adjusted between heights 88 cm and 225 cm. Other technical features include polarised magnets at each end of the top rail, a gift to those that want to create impressive back drops or panoramas with any system from the Maxibit Solo range. Solo 1 is cost effective and can be use together with the Maxibit brochure holder.

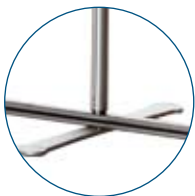

### Maxibit Solo 2

Solo 2 is an ultra compact campaign tool that recognises the need for double sided displays. With the ability to promote your brand in two directions, Solo 2 is 82 cm wide and can be adjusted in height from as little as 88 cm to a towering 225 cm. When used alone, Solo 2 can grab a crowd's attention out in the front, while the polarised magnets, anchored at each end of the top rail, will allow you to connect multiple Solos to create impressive backdrops and ambience from behind. Accessories include a Maxibit brochure holder and an I-lite spotlight to accent your brand even more.



### Maxibit Solo 3

Maxibit Solo 3 is the pinnacle of the Solo range. Employing contemporary design and an elevated graphic, Solo 3 sits firm on its stylish tripod foot. The polarised magnets hidden in the top rail provide each user the potential to use a number of Solos to connect and create a portable marketing extravaganza. With the choice of two widths, a free-standing 60 cm Solo 3 will create impressive flag banners, while an 82 cm Solo 3 will accentuate your brand further. Adjustable in height from 88 cm to 225 cm, each Solo 3 is undoubtedly enhanced by an I-lite spotlight or a plexiglass Maxibit brochure holder.



Buyer's Guide	Solo 1	Solo 2	Solo 3
82 cm width	•	•	•
60 cm width			•
Carrying bag	•	•	•
Adjustable graphic height	•	•	•
Lock secured pole	•	•	•
Foot visible from front	•		
Base area	1353 cm <sup>2</sup>	1456 cm <sup>2</sup>	1512 cm <sup>2</sup>
Magnetic ends	•	•	•
Slide-in graphics	•	•	•
Double sided		•	•
Tools required	No	No	No
Weight for 82 cm*	2.44 kg	1.80 kg	2.23 kg
Weight for 60 cm*			1.59 kg

\*complete system with bag

#### Why choose a banner stand

- Great in malls, stores, conferences etc
- Three striking designs
- Lightweight for easy carrying
- Low cost campaign tool
- Double sided
- Adjustable banner height, 88 cm–225cm
- Two standard widths 60 cm and 82 cm
- Quick and easy graphic exchange
- Magnetic end caps allow Solo stands to be connected together
- Easy set-up

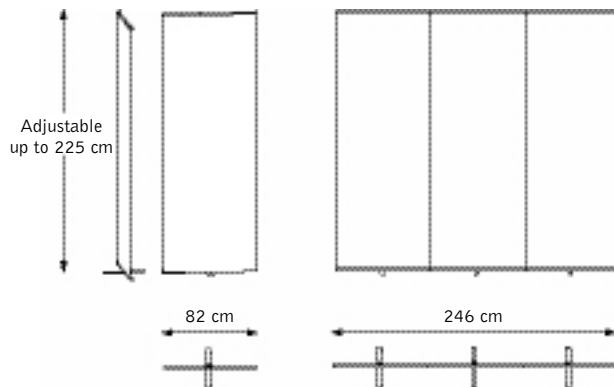

#### Specification: Maxibit Solo

Versions: Solo 1, Solo 2, Solo 3

Construction: Roll-up aluminum alloy cassette with a built-in foot. Bag included.

Graphic material: Fabric or inkjet graphics.

Width: 60 cm or 82 cm.

Height: Adjustable up to 225 cm.

Weight: 1.2 kg excl. graphics and bag.

Compact Displays (UK) Ltd.

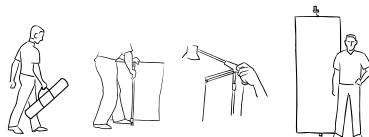

The Original Since 1978